



# MST01 ■ Stand with gas spring 14"-22"



## Features

- 1 ADJUSTABLE DISTANCE FROM USER  
from 284 mm to 749 mm
- 2 KEYBOARD AND MOUSE MOUNT
- 3 FLOOR-MOUNTED BASE

## Technical Data

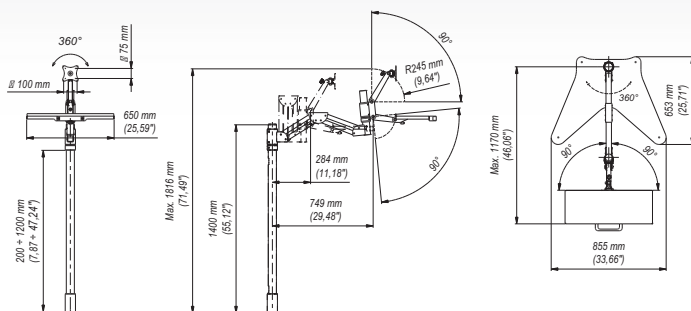

- 75x75 mm  
100x100 mm
- 14"-22"
- 20 Kg
- min. 75x75 mm  
max. 100x100 mm
- 1047 mm
- 90°/90°
- 90°/90°
- 360°

## Trade Information

Index	Colour	Package	EAN
MST01c-B	■	■	5908252963126
MST01s-B	■	■	5908252963133
MST01w-B	□	■	5908252963140

Package Dimensions [mm] (H x W x D)	<b>1830x870x660</b>
Weight [Kg]	<b>35</b>

## Accessories

Series GDA

